



Effluent Filters

EF-ML3-910, EF-ML3-916, EF-ML3-932,
EF-ML3-964

Features

- Patented effluent filters for residential/commercial applications
- Durable dual handle construction
- Supplementary support/entrance extension base available
- Gas transport opening

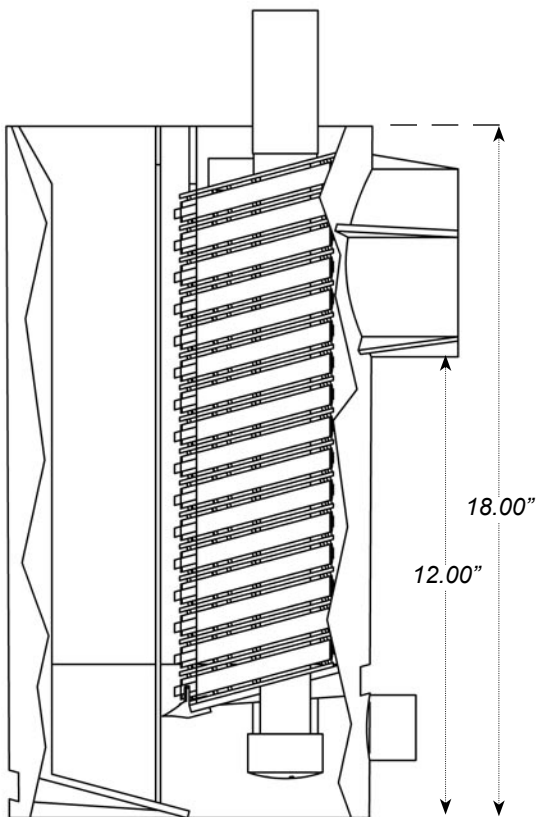
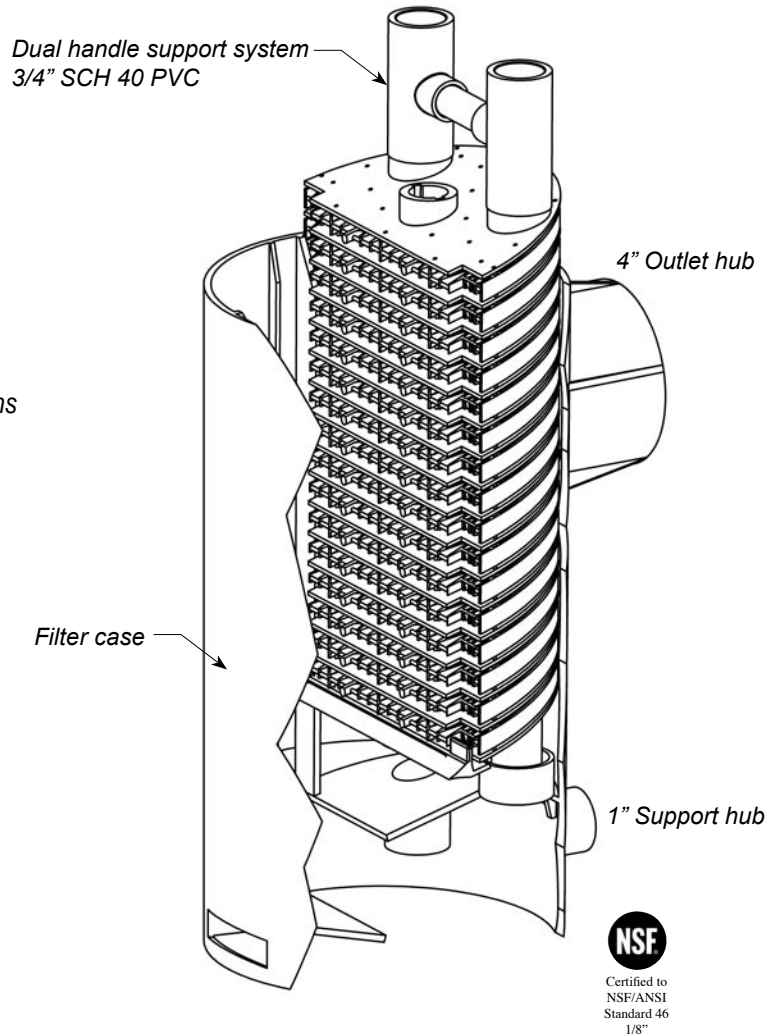
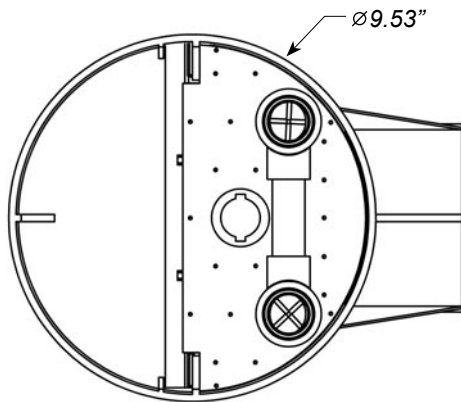

MODEL	LID COLOR	GPD	FILTRATION	LINEAR FT OF WEIR
EF-ML3-910	BLACK	3350	1/10"	49.02
EF-ML3-916	BLUE	2750	1/16"	49.02
EF-ML3-932	GREEN	2750	1/32"	49.02
EF-ML3-964	RED	1500*	1/64"	51.6

*High water audio visual alarm is suggested due to the high level of filtration and the subsequent short service interval for these commercial/industrial filters.

Materials/Specs

Filter Cartridge

- Injection molded polypropylene plastic

Case

- Injection molded ABS
- Outlet hub accepts 4" SCH 40 or SDR 35
- Gas transport opening

Warranty for Defects in Material and Workmanship

- 1 year from date of purchase

1-877-QUANICS - www.quanics.net

Quanics
Engineering Water Solutions®

© 2011, Quanics Inc. All rights reserved.
Product(s) covered by one or more U.S.
and/or International patents. Other U.S. and
International patents may be pending.

DOWNLOAD
AutoCAD
DRAWINGS