



Recirculation Device 1.25" Inlet - 80/20 split

ATS-GRD-80/20, ATS-GRD-80/20-N

80/20 Features

- Gravity recirculation provides 80% recirculation to treatment media dosing tank and 20% dispersal
- Pre-plumbed inside a riser
- Installs over opening of recirculation tank
- For flows up to 1.59 gpm or 2,289 gpd
- Extra extension risers may be installed to bring to grade
- Automatic recirculation, no adjustments

80/20-N Features

- Gravity recirculation provides 80% recirculation to initial septic tank and 20% dispersal
- Pre-plumbed inside a riser or basin to install on recirculation tank opening or freestanding
- For flows up to 1.59 gpm or 2,289 gpd
- Extra extension risers may be installed to bring to grade
- Automatic recirculation, no adjustments
- Nitrogen reduction carriage

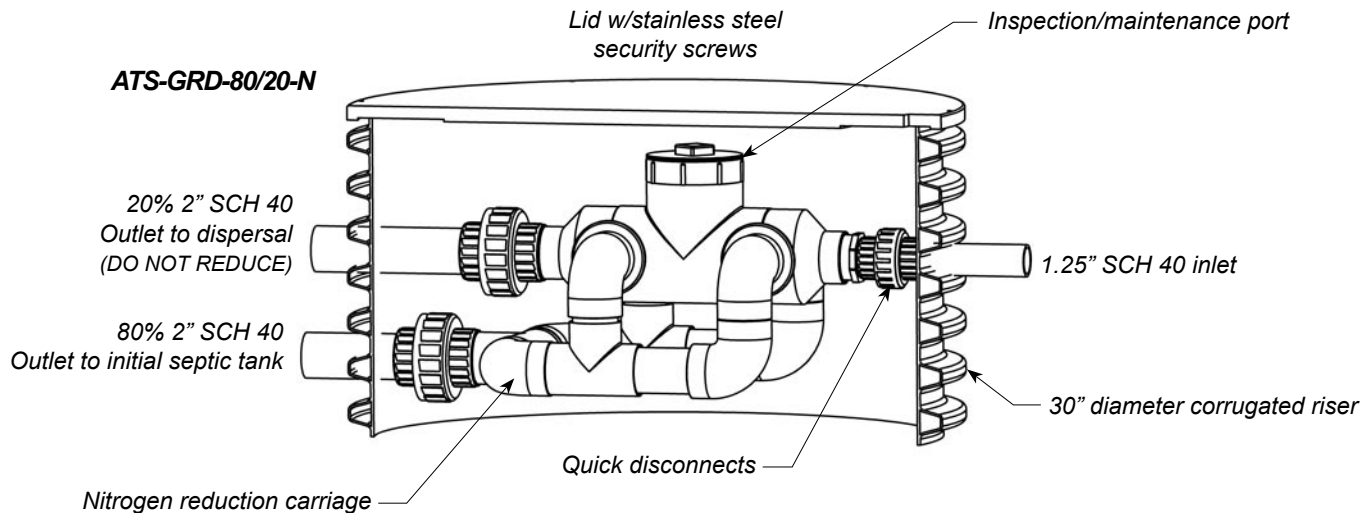
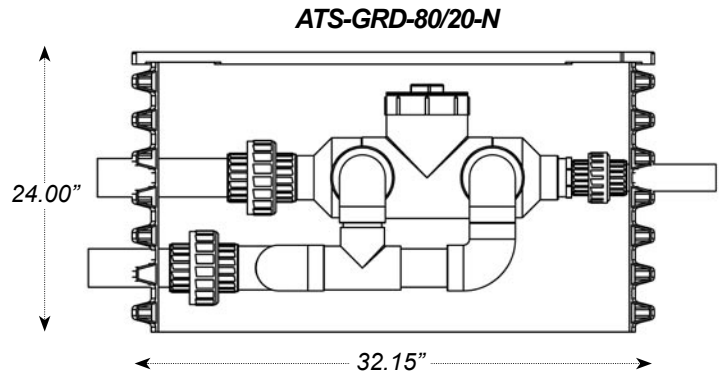
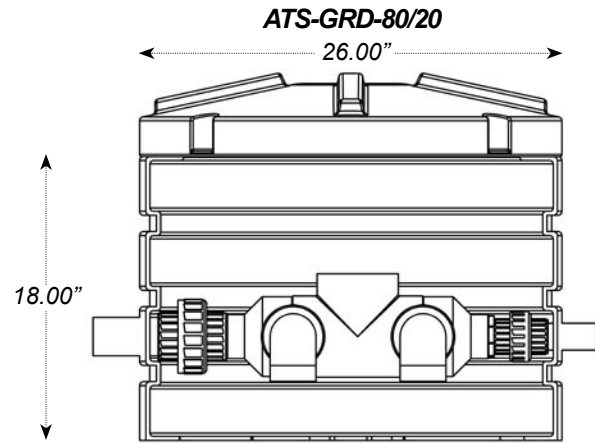

Materials

Riser and Lid

- Tamper resistant screws - stainless steel
- Lid - 80/20 = Polyethylene plastic, 80/20-N = Polyethylene plastic
- Riser - 80/20 = Polyethylene plastic, 80/20-N = Corrugated PVC plastic

Internal components

- SCH 40 PVC piping
- Rubber Grommets

Warranty for Defects in Material and Workmanship

- All components - 1 year from date of purchase

AutoCad R-14 dwg files at www.quanics.net

Pricing page 16

**Also Available
in 4" & 6" models
for larger flows**

1-877-QUANICS - www.quanics.net

Quanics
Engineering Water Solutions

© 2011, Quanics Inc. All rights reserved.
Product(s) covered by one or more U.S.
and/or International patents. Other U.S.
and International patents may be pending.

DOWNLOAD
AutoCAD
DRAWINGS