



Gravity Recirculation Device

1.25" Inlet - 100/80/20 split

ATS-GRD-100/80/20

Features

- Gravity Recirculation Device provides 80% recirculation
- During times of no flow, float valve changes recirculation rate to 100%
- Installed directly over pump tank opening
- Ideal for use on vacation or weekend homes
- Float valve is field adjustable for proper placement

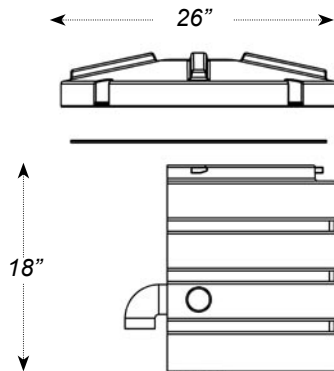

ATS-GRD-100/80/20

Also Available
in 4" & 6" models

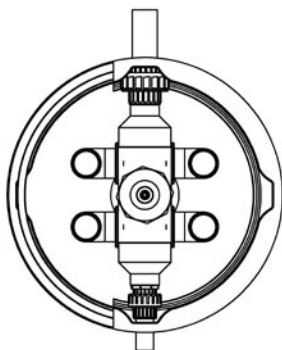

26" x 18" Cast-in riser and lid

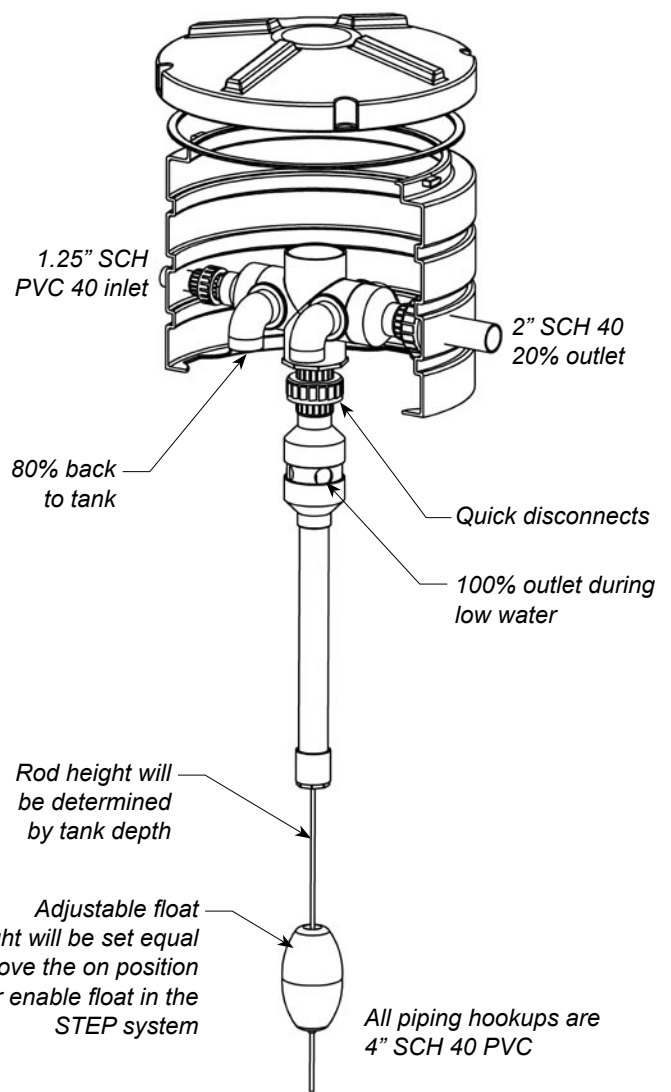

Materials

Riser and Lid

- High density non-corrosive polyethylene plastic
- Tested to withstand up to a 2500 lb wheel load
- Neoprene gasket
- Stainless steel tamper resistant hardware
- 26" diameter lid

Effluent Discharge Assembly

- 2" SCH 40 PVC Pipe
- Rubber Grommets

Float Valve Assembly

- 60" Stainless steel rod
- Polypropylene float

Warranty for Defects in Material and Workmanship

- All components - 1 year from date of purchase

AutoCad R-14 dwg files at www.quanics.net

1-877-QUANICS - www.quanics.net



© 2011, Quanics Inc. All rights reserved.
Product(s) covered by one or more U.S.
and/or International patents. Other U.S.
and International patents may be pending.

