



STEP System

(Turbine Pump Retrofit Septic Tank Package)

SS-200-10/20/30

Features

- Designed for higher performance onsite systems where high heads are required
- Includes all components for pump installation into either a primary tank or pump tank
- Includes a 10, 20 or 30 plus gpm turbine effluent pump
- Additional risers may be added for deeper installations

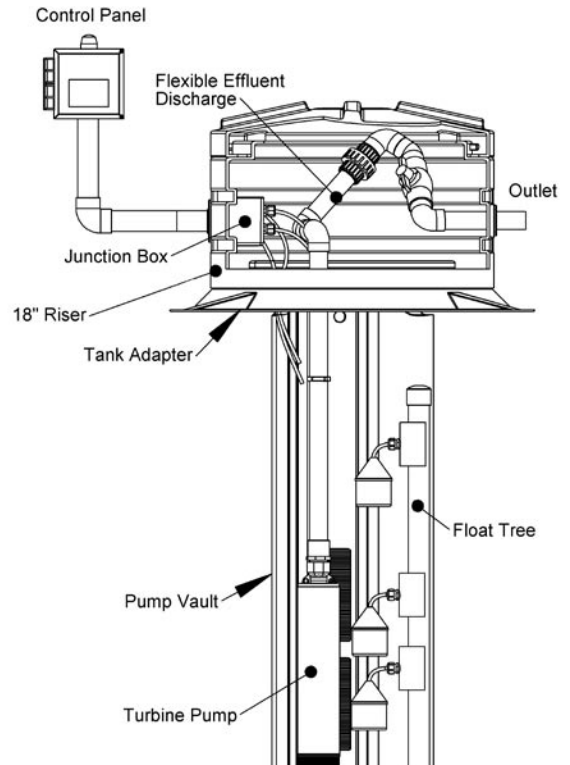
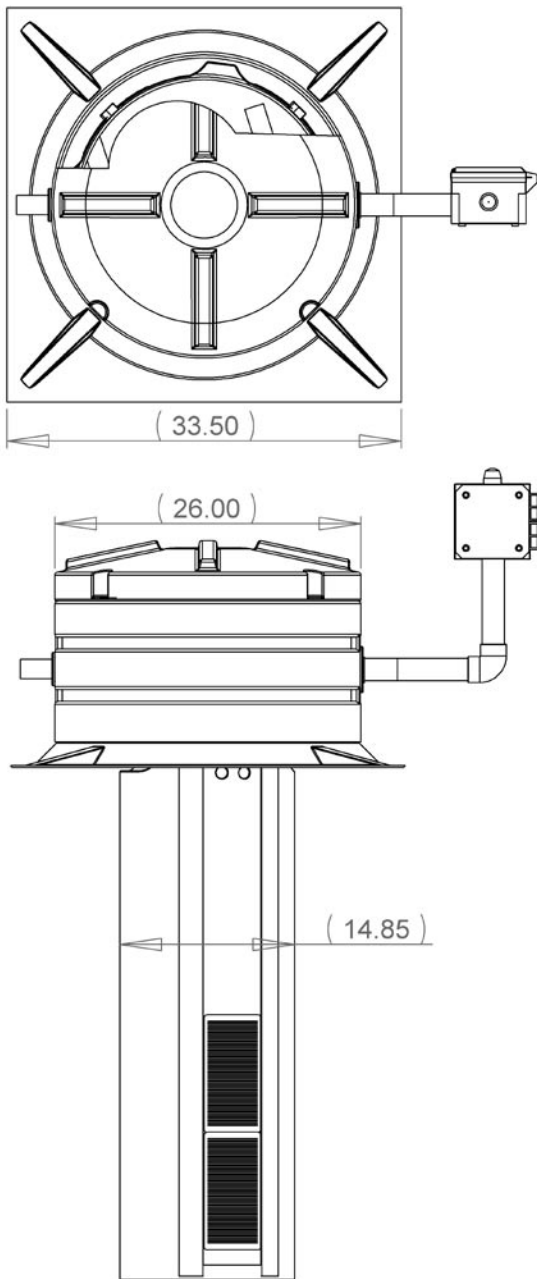

Components

- **FPV-H44-4:** 44" filtered pump vault with 2 filter plates
- **RB-R-26x2:** 26" x 2" retrofit tank adapter
- **RB-R-26x12:** 26" x 12" riser
- **RB-L-26:** 26" lid
- **P-TE-10/20/30-Plus:** 1/2 hp, 10, 20 or 30 gpm turbine effluent pump
- **PDS-EDF-1.25:** 1.25" flexible effluent discharge
- **PDS-GT-1.25:** 1.25" water-tight grommet
- **AC-JSB-4:** Junction splice box with 4 cord grips
- **AC-CP-S-C:** Simplex contactor control panel
- **PDS-GT-1.50:** 1.5" water-tight grommet

Warranty for Defects in Material and Workmanship

- **Pump** - 3 Years
 - **Alarms/controls** - 3 Years
 - **Risers and lids** - 2 Years
 - **Filtered vault** - 1 Year
 - **All other components** - 1 Year
- AutoCad files at www.quanics.net

1-877-QUANICS - www.quanics.net

Quanics
Engineering Water Solutions®

© 2007, Quanics Inc. All rights reserved.
Product(s) covered by one or more U.S.
and/or International patents. Other U.S. and
International patents may be pending.

DOWNLOAD
AutoCAD
DRAWINGS