

STEP System

(Effluent Pump Retrofit Septic Tank Package)

SS-100, SS-110

Features

- Designed for most onsite applications where simply lifting effluent up hill is required
- Includes all components for pump installation into either a primary tank or pump tank
- Retrofit tank adapter allows installation into existing concrete tanks
- Additional risers may be added for deeper installations
- Includes effluent pump

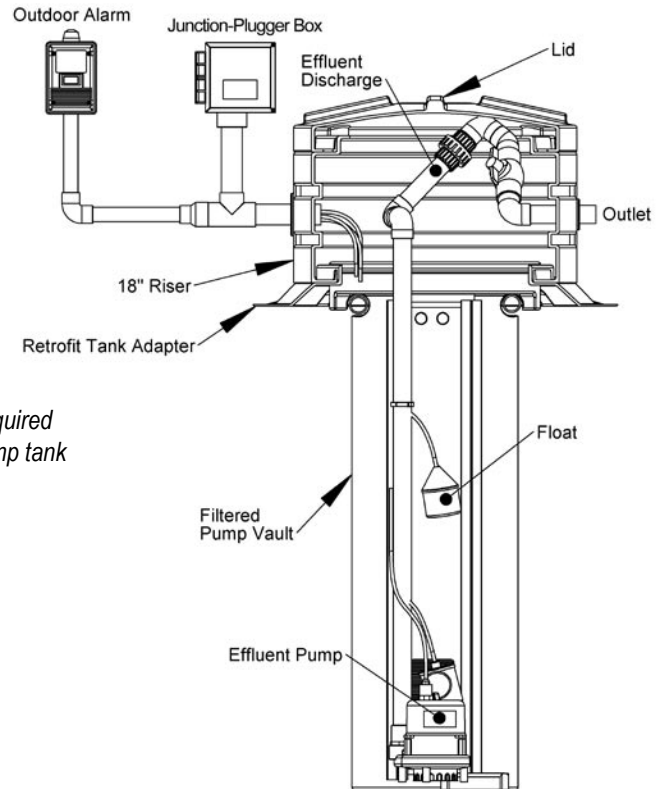
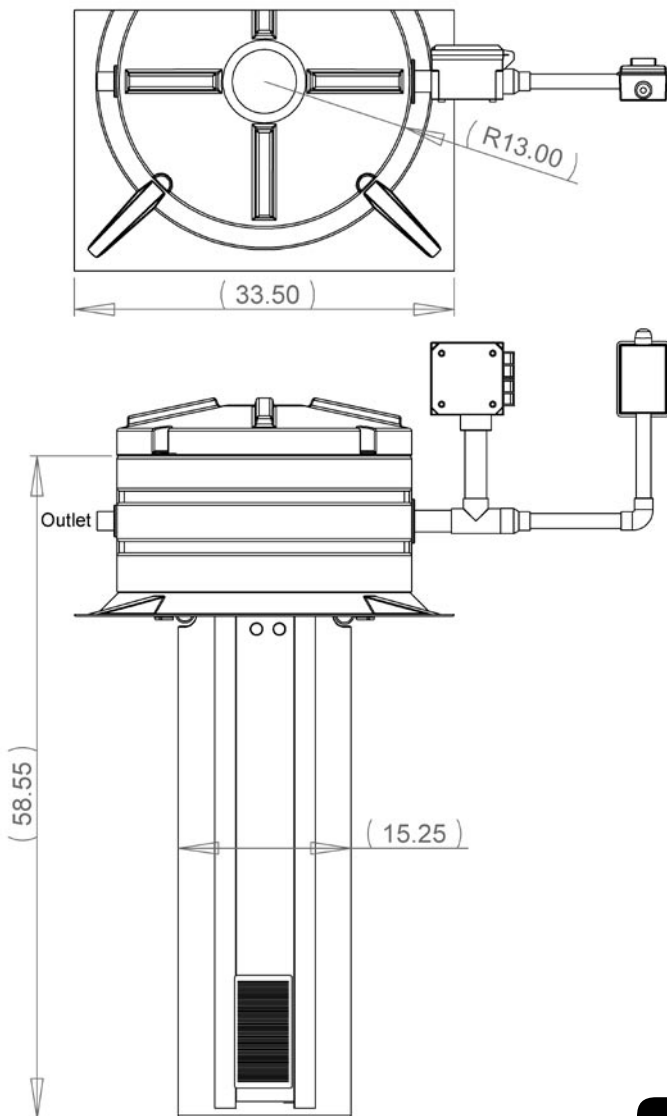

Components

- **FPV-H44-4:** 44" filtered pump vault with 2 filter plates
- **RB-R-26x2:** 26" x 2" retrofit tank adapter
- **RB-R-26x12:** 26" x 12" riser
- **RB-L-26:** 26" Lid
- **P-SE-13T:** 1/3 hp submersible effluent pump
- **PDS-EDF-1.5:** 1.5" flexible effluent discharge
- **PDS-GT-1.5:** 1.5" water-tight grommet
- **AC-JPB:** Junction plug box
- **AC-A-O:** Indoor/outdoor high water alarm

SS-110 model upgrades:

- **P-SE-12T:** 1/2 hp effluent pump
- **PDS-EDF-2.0:** 2" flexible effluent discharge
- **PDS-GT-2.0:** 2" water-tight grommet

Warranty for Defects in Material and Workmanship

- **Pump** - 3 Years
- **Alarms/controls** - 3 Years
- **Tank adapter, riser and lid** - 2 Years
- **Filtered vault** - 1 Year
- **All other components** - 1 Year

AutoCad files at www.quanics.net

1-877-QUANICS - www.quanics.net