



## Risers & Lids

(24" Diameter)

RB-L-24, RB-R-24x12, RB-R-24x24, RB-R-24x36,  
RB-R-24x48, RB-R-24x60, RB-R-24x72, RB-R-24x84

### Features:

- Heavy duty for deep installations
- Larger diameters provide easier access to buried components
- May be cast-in or retrofit to any concrete tank
- Heights available in 1' increments up to 7'

RB-L-24 (Lid)



RB-R-24x24 (Riser)

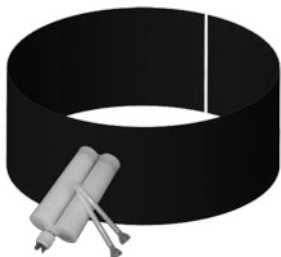
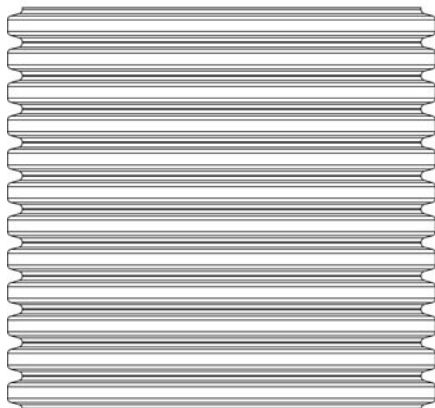
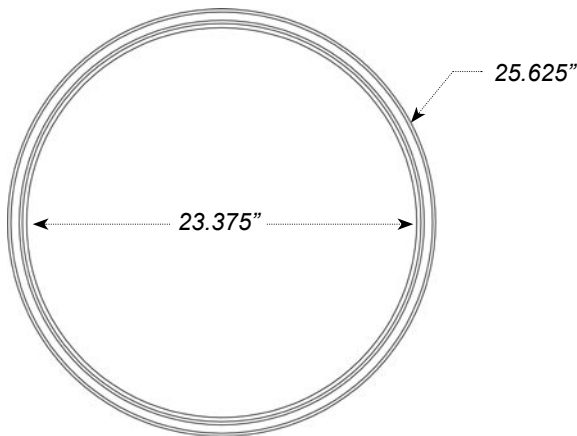

Splice kits available and recommended at 7'

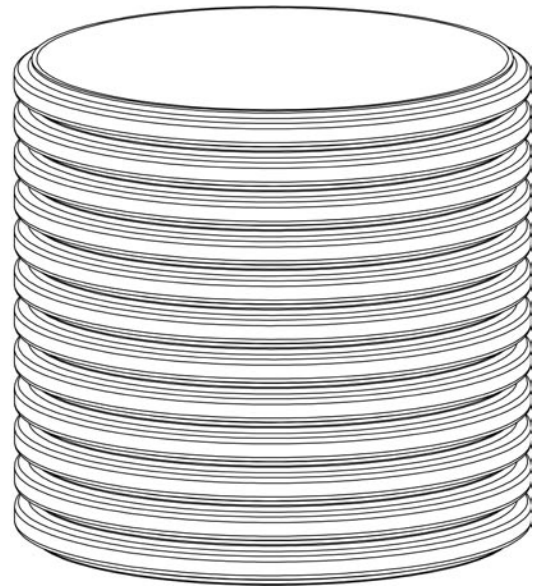

RB-RTA-24  
(Retrofit Tank Adapter)

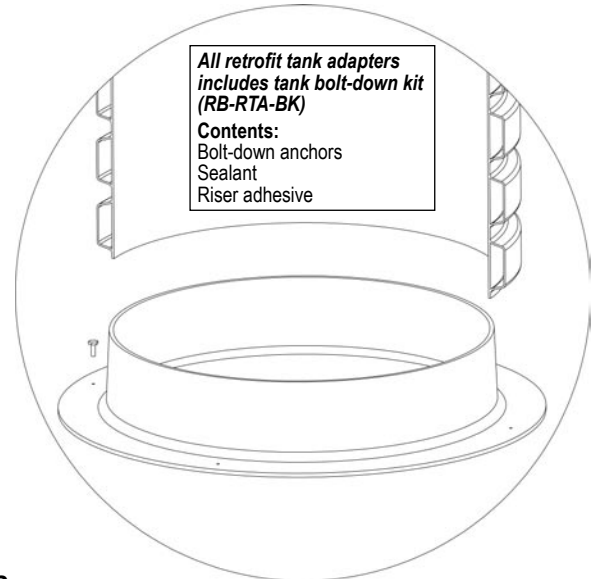

### Materials:

#### Risers and lids

- High density PVC
- Stainless steel screws

#### Warranty for Defects in Material and Workmanship

- 1 year from date of purchase

#### IMPORTANT:

- When adding risers together for deeper installations Quanics does not recommend exceeding a maximum depth of 14'
- Supplied bolt-down kit and/or riser adhesive must be installed as per instructions
- To prevent unauthorized entry install all fasteners as per instructions

AutoCad files at [www.quanics.net](http://www.quanics.net)

**1-877-QUANICS - [www.quanics.net](http://www.quanics.net)**



© 2009, Quanics Inc. All rights reserved.  
Product(s) covered by one or more U.S.  
and/or International patents. Other U.S. and  
International patents may be pending.

