

## Recirculation Devices (Gravity/Pressure)

ATS-GRD-4/1, ATS-PRD-4/1

### Features

- Gravity/pressure recirculation device provides 80% recirculation
- Pre-plumbed inside a polyethylene basin
- Extra extension risers may be added to bring up to grade
- Easily set by water leveling outlets

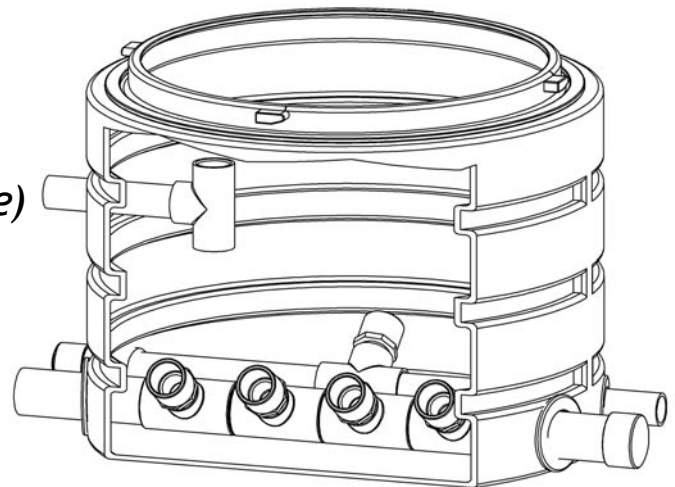

**Also available in other pipe sizes for larger flows!**

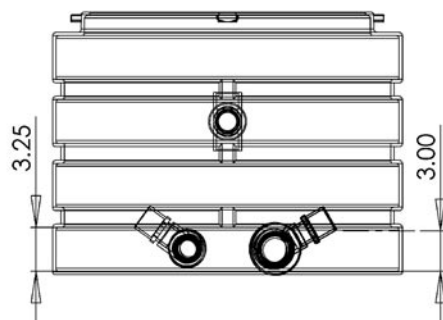
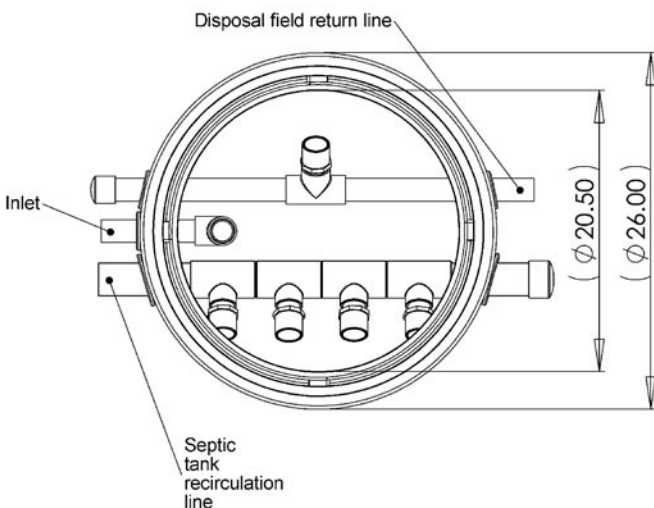
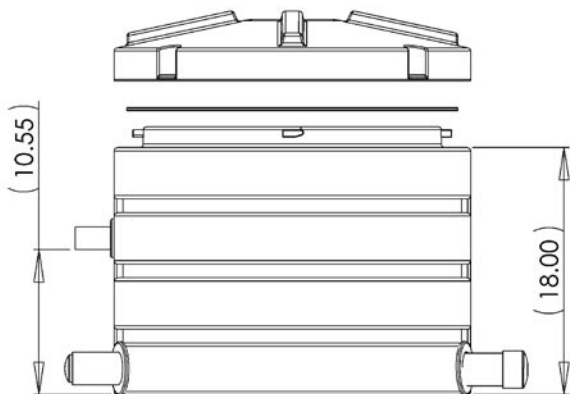

## Recirculation Devices (Pressure) ATS-PRD-4/1

### Features

- Provides 80% recirculation
- Pre-plumbed for quick installation
- Attaches to 4" septic tank inlet pipe
- Pressure setting pipe included

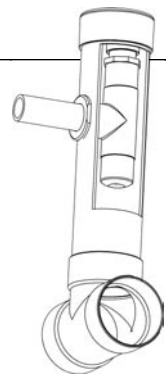

### Materials

#### Basin and lid

- High density non-corrosive polyethylene plastic
- Tested to withstand up to a 2500 lb wheel load
- Neoprene gasket
- Stainless steel tamper resistant hardware
- 26" diameter lid

#### Effluent discharge assembly

- Inlet line: 1.25" SCH 40 PVC pipe
- 20% discharge line: 1.25" SCH 40 PVC pipe
- 80% recirculation line: 2" SCH 40 PVC pipe
- Water-tight grommets

#### Warranty for Defects in Material and Workmanship

- Basin and lid - 2 Years
- Effluent discharge assembly - 1 Year

AutoCad dwg files at [www.quanics.net](http://www.quanics.net)

**1-877-QUANICS - [www.quanics.net](http://www.quanics.net)**