



Recirculation Devices (Gravity)

ATS-GRD-100/50, ATS-GRD-100/50/50,
ATS-GRD-100/50/50-N

Features

Features

- Gravity Recirculation Device provides 50% recirculation
- During times of no flow, float valve changes recirculation rate to 100%
- Installed directly over pump tank opening
- Ideal for use on vacation or weekend homes
- Float valve is field adjustable for proper placement
- Nitrogen reduction model (ATS-GRD-100/50/50-N)

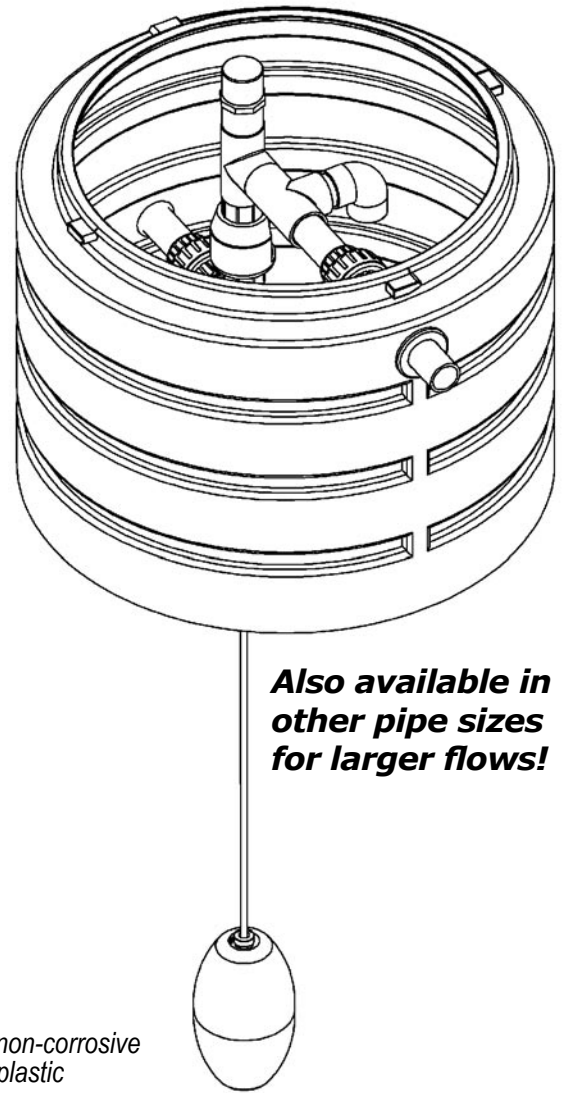
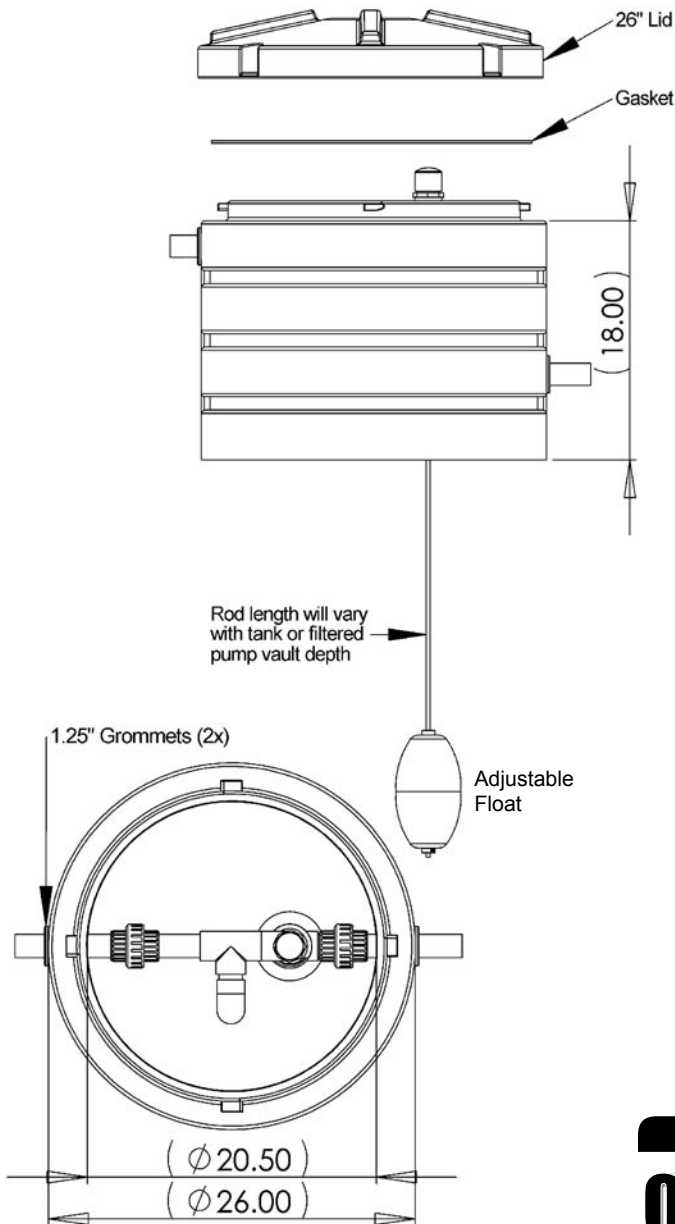

**Also available in
other pipe sizes
for larger flows!**

Materials

Riser and lid

- High density non-corrosive polyethylene plastic
- Tested to withstand up to a 2500 lb wheel load
- Neoprene gasket
- Stainless steel tamper resistant hardware
- 26" diameter lid

Effluent discharge assembly

- 1.25" SCH 40 PVC Pipe
- Water-tight grommets

Float valve assembly

- 60" stainless steel rod
- Polypropylene float

Warranty for Defects in Material and Workmanship

- **Basin and lid** - 2 Years
- **Effluent discharge assembly** - 1 Year

AutoCad dwg files at www.quanics.net

1-877-QUANICS - www.quanics.net

Quanics
Engineering Water Solutions®

© 2007, Quanics Inc. All rights reserved.
Product(s) covered by one or more U.S.
and/or International patents. Other U.S. and
International patents may be pending.

DOWNLOAD
AutoCAD
DRAWINGS