

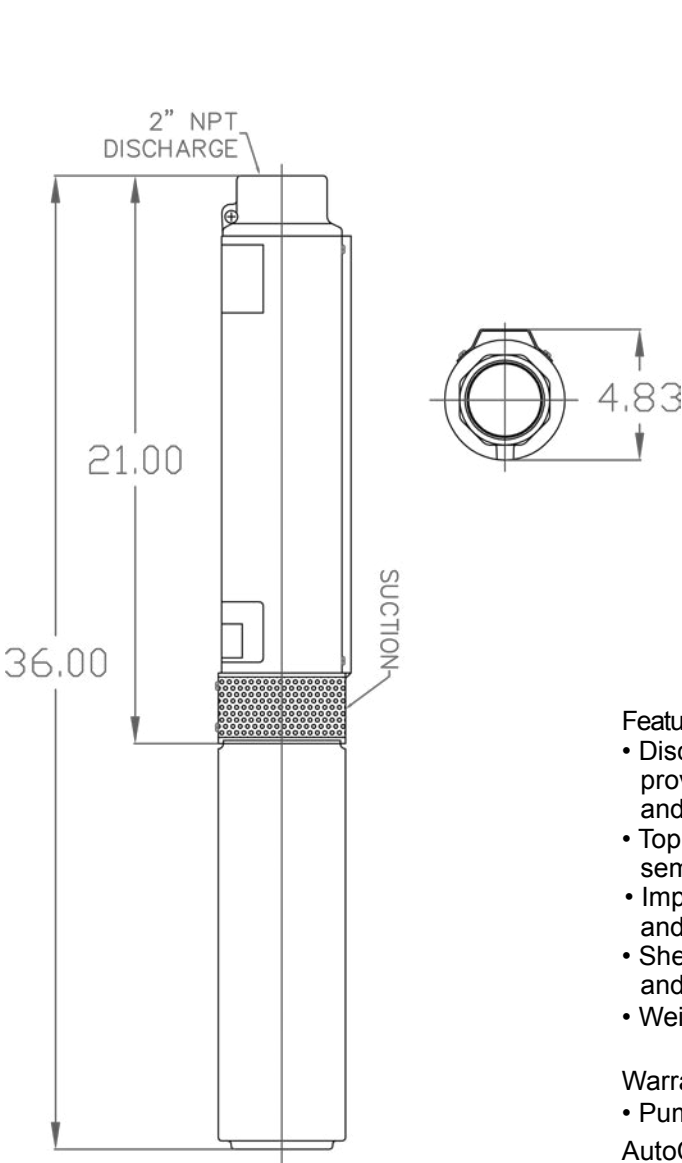

Replacement Parts Pumps (Turbine)

P-TE-90

The 90 GPM Stainless Steel High-Flow 4" Submersible Pump delivers efficient and dependable performance even in rough, aggressive water. Heads to 115 feet and capabilities to 150 GPM. Built to deliver long term, trouble free service.



H.P.	2
Discharge	2" NPT
Volts	230
Wiring	3-wire

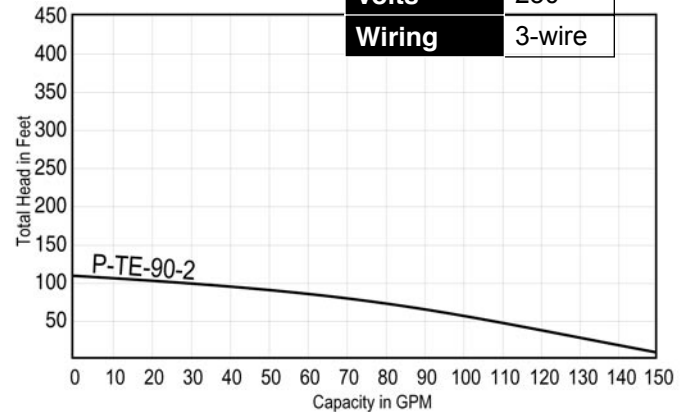

Features:

- Discharge - Heavy duty 300 grade stainless steel construction provides smooth water passage to column pipe. Large wrench flats and rope hole
- Top Bearing - Field proven, sealed and lubricated top bearing assembly keeps abrasives out, ensuring long bearing life.
- Impellers - 20% glass reinforced polycarbonate to resist abrasives and provide smooth water passage for minimal friction loss
- Shell - Heavy gauge 300 series stainless steel pump shell is durable and offers high corrosion resistance
- Weight - 45 lbs. w/20' power cord

Warranty for Defects in Material and Workmanship

- Pumps - 3 Years

AutoCad R-14 dwg files at www.quanics.net

1-877-QUANICS - www.quanics.net

Quanics
Engineering Water Solutions™

© 2006, Quanics Inc. All rights reserved.
Product (s) covered by one or more U.S.
and/or International patents. Other U.S.
and International patents may be pending.

DOWNLOAD
AutoCAD
DRAWINGS