

## Pumps (Sump) P-SU-13T

### Features

- Rugged cast iron pump body and motor cover, exterior hardware stainless steel construction
- Carbon/ceramic mechanical seal
- Piggy-back style float for automatic or manual operation
- Oil-filled motor with automatic reset overload provides safe operation
- Ball bearing construction for long life
- Designed for septic effluent applications

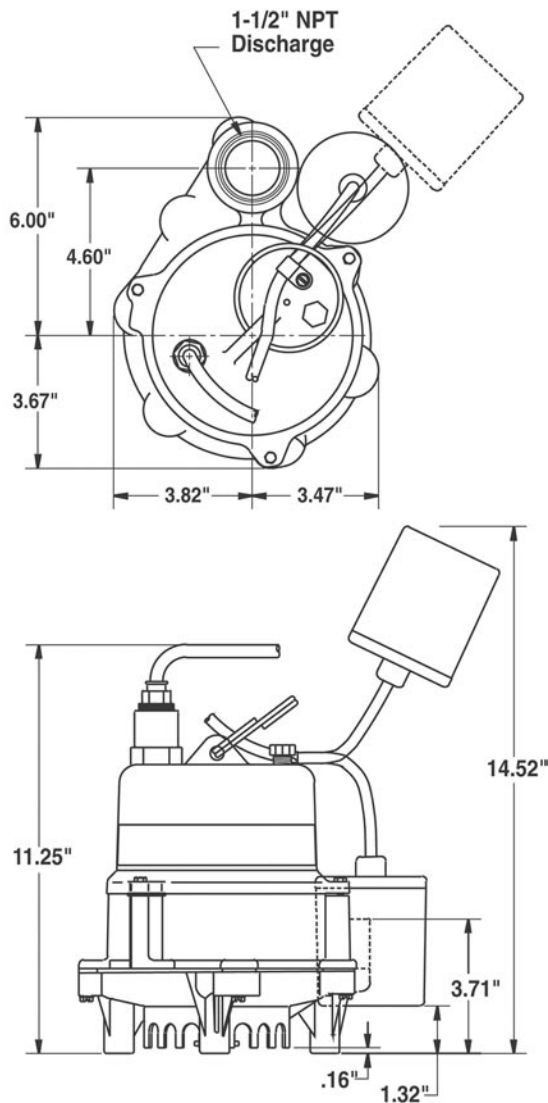

### Specifications

**Capacities:** 40 GPM @ 10' head

**Heads:** To 25'

**Motor:** 1/3 HP = 9.8FLA shaded pole with thermal overload protection

**Electrical:** 115V, 1Ph, 60Hz

**Operation:** Tethered float, on/off

**Impeller:** Thermoplastic, vortex type

**Solids handling:** 1/2" (12.7mm)

**Power cord:** 10' (3M) or 20' (6M) 16-3, SJTW-A/SJTW

**Discharge:** 1-1/2"

**Warranty for Defects in Material and Workmanship**

- 3 Years

AutoCad dwg files at [www.quanics.net](http://www.quanics.net)

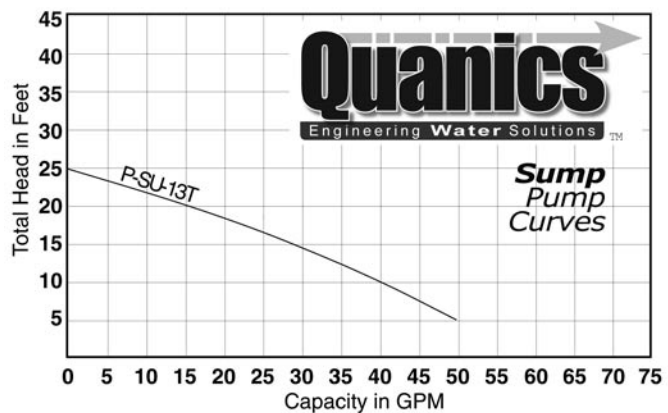

**1-877-QUANICS - [www.quanics.net](http://www.quanics.net)**

**Quanics**  
Engineering Water Solutions®

© 2007, Quanics Inc. All rights reserved.  
Product(s) covered by one or more U.S.  
and/or International patents. Other U.S. and  
International patents may be pending.

DOWNLOAD  
AutoCAD  
DRAWINGS