

Pumps (Effluent) P-SE-10T

Features

- Cast iron construction
- Carbon/ceramic mechanical seal
- Piggy-back style float for automatic or manual operation
- Oil-filled motor with automatic reset overload provides safe operation
- Designed for septic effluent applications

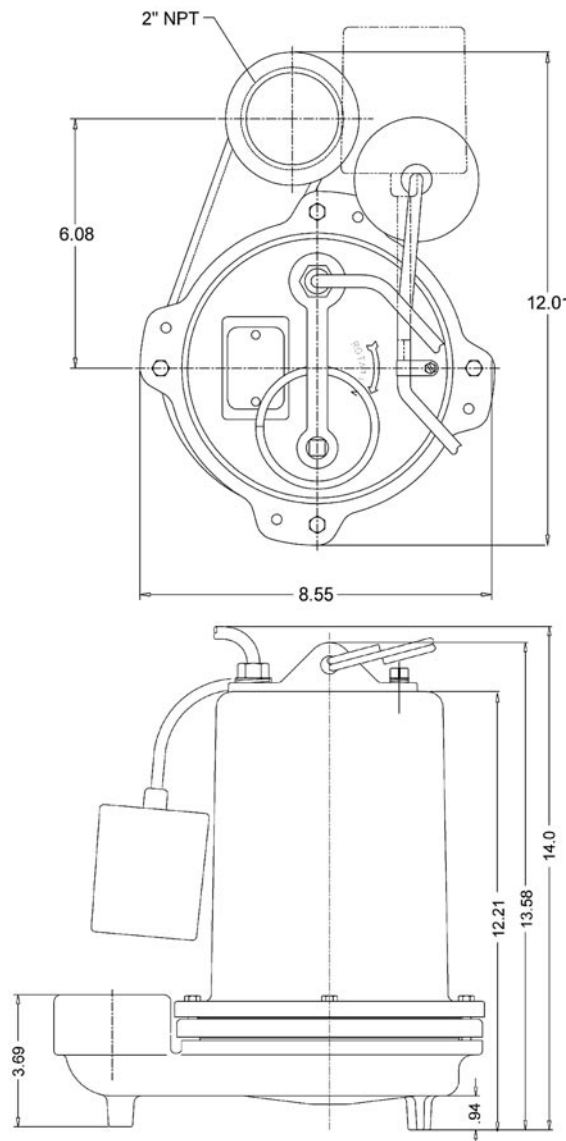

Specifications

Capacities: 96 GPM @ 10' head

Heads: To 72'

Motor: 1 HP, PSC with thermal overload

Electrical: 230V, 6.6FLA, 1Ph, 60Hz

Operation: Tethered float

Impeller: Cast iron, non-clog, open vane type

Solids Handling: 3/4" (19mm)

Power Cord: 10' (3M) or 20' (6M) 16-3, SJTW-A/SJTW

Discharge: 2"

Warranty for Defects in Material and Workmanship

- 3 Years

AutoCad dwg files at www.quanics.net

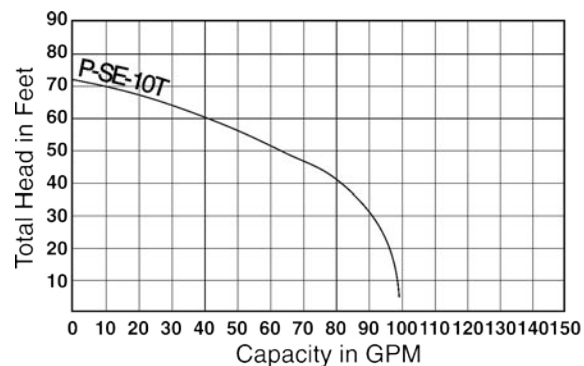

1-877-QUANICS - www.quanics.net

Quanics
Engineering Water Solutions®

© 2007, Quanics Inc. All rights reserved.
Product(s) covered by one or more U.S.
and/or International patents. Other U.S. and
International patents may be pending.

DOWNLOAD
AutoCAD
DRAWINGS