

Alarms & Controls Plunger Box

AC-JPB

Features:

- NEMA 4X enclosure rated for outdoor use
- Hinged cover for convenience
- Receptacle for pump & pump switch
- Terminal strip for high water alarm

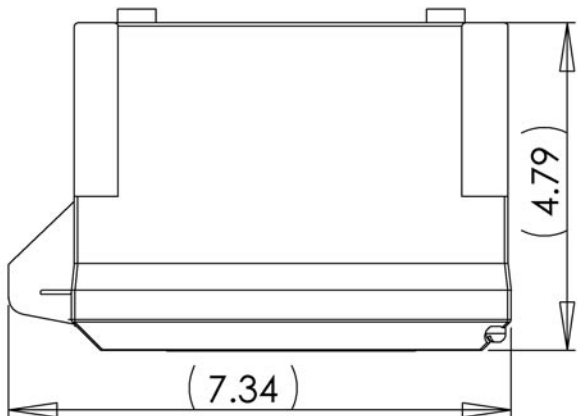
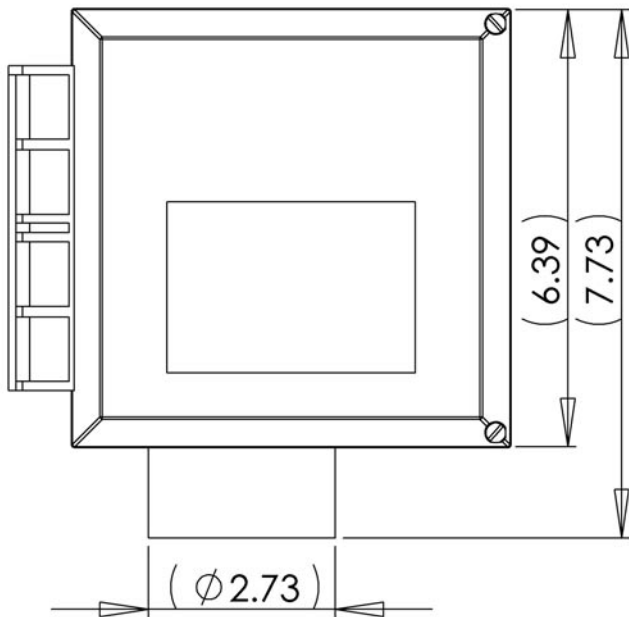

Specifications

Enclosure

- High impact, corrosion resistant thermoplastic
- Weatherproof
- 2" terminal adapter hub

Voltage

- 120 VAC primary voltage

Receptacle

- 120 VAC - NEMA type 5-15; 230 VAC NEMA type 6-15

Cord Seal

- Liquid-tight cord seal with strain relief

Warranty for Defects in Material and Workmanship

- 3 Years

AutoCad dwg files at www.quanics.net

1-877-QUANICS - www.quanics.net