



Alarms & Controls

Alarms (High Water Alarm)

AC-A-O, AC-A-O-AC

Features

- High water alarm for indoor/outdoor use
- Red warning beacon, alarm test switch, and horn silence switch
- Includes mercury float
- AC-A-O-AC model includes auxiliary contacts

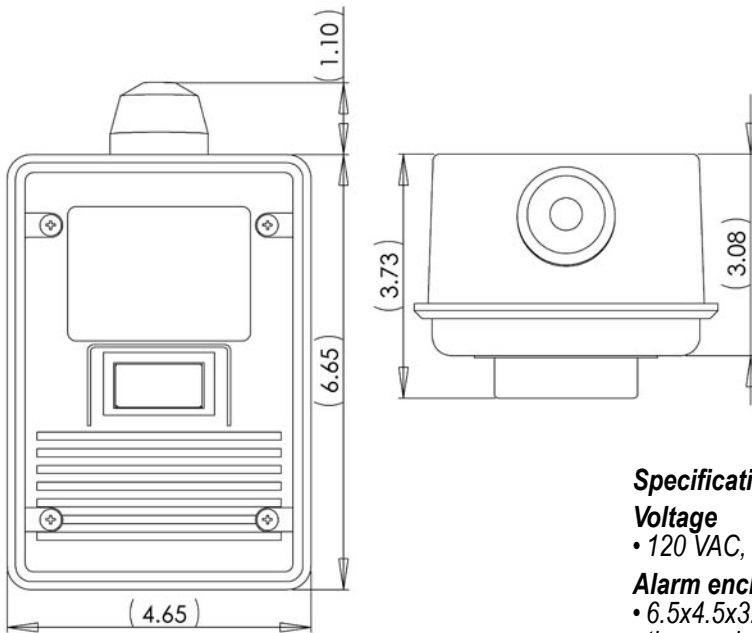
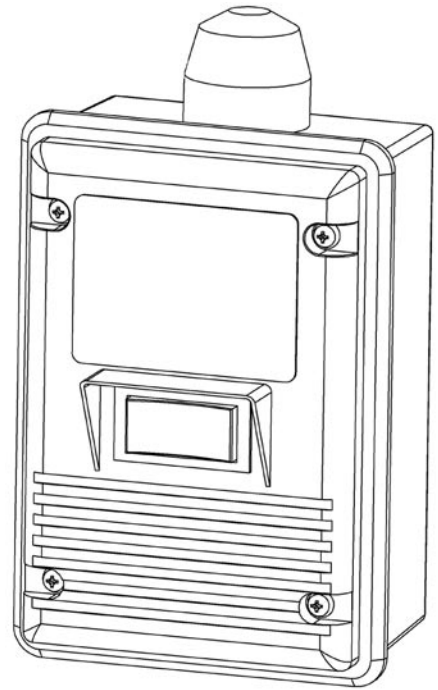

Specifications

Voltage

- 120 VAC, 50/60 Hz, 7 watts max. (alarm condition)

Alarm enclosure

- 6.5x4.5x3.0 inch (16.51x11.43x7.62 cm), indoor-outdoor, weatherproof, thermoplastic meets 3R water-tight standards

Alarm horn

- 85 decibels at 10 feet

Alarm beacon

- Meets Type 3R water-tight standards as installed by factory

Test/Silent Switch

- Certified to IP66 and IP68 standards

Float Switch

- Sensor float control switch with mounting clamp

Cable

- 15 feet (4.57 meters), flexible 18 gauge, 2 conductor (UL) SJOW water-resistant (CPE)

Float

- Mercury float switch

Warranty for Defects in Material and Workmanship

- AC-A-O, AC-A-O-AC - 3 Years

AutoCad dwg files at www.quanics.net

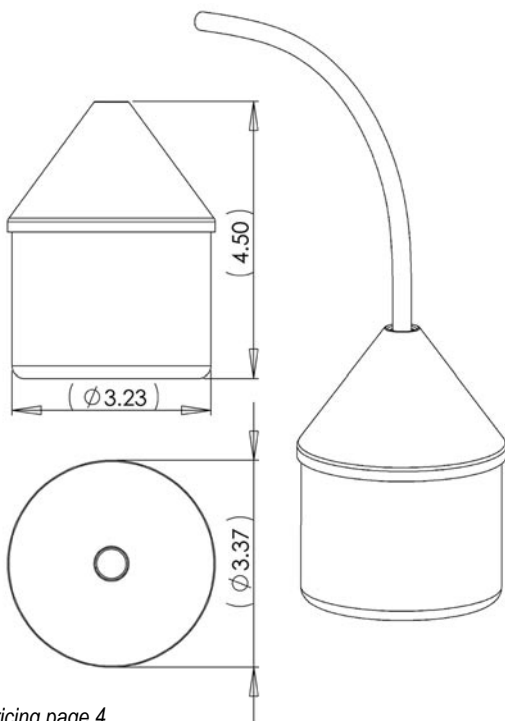

1-877-QUANICS - www.quanics.net

Quanics
Engineering Water Solutions®

© 2007, Quanics Inc. All rights reserved.
Product(s) covered by one or more U.S.
and/or International patents. Other U.S. and
International patents may be pending.

DOWNLOAD
AutoCAD
DRAWINGS