

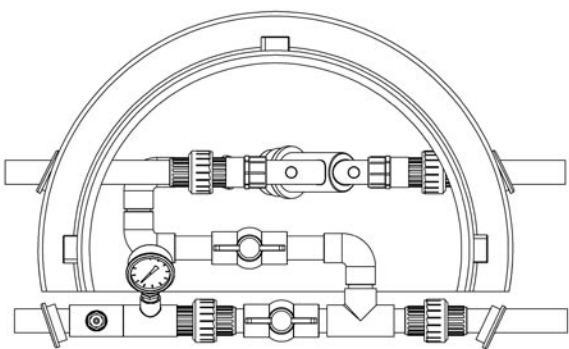

# Drip Irrigation

A Ubu Ya Ybh Gng Ya g  
 D8GA G%5I HZ'D8GA G%)!5I HZ'D8GA G&5I HZ'  
 D8GA G%A 5BZ'D8GA G%)!A 5BZ'D8GA G&A 5B

:YhifYg  
 ACE~c [ { æc^âA { æ } æ \* ^ { ^ } cA . ^ c { A ~ cãjã : ^ ââc [ A ] : [ çãâ^A  
 àæ& \A , æ • @ã } \* A [ -Aã ]ã } A , ^ | âAæ } âA • ]ã } A , | c ^ !  
 AU' ^ Eæ • • ^ { à | ^ âA , âc @Aæ | | A } ^ & ^ • • æ ! ^ A & [ { } ] { } ^ } c •  
 ACE~c [ { æc^âA { ~ • cA à ^ A ~ • ^ âA } A & [ ] b } } & cã [ ] A , âc @Aæ A ÚÓÜË  
 ÖP VU A & [ ] c : [ | | ^ E A T æ } ~ æ | A / ^ ~ ã / ^ A cã { ^ âA & [ ] } c : [ | | ^ E  
 A Ø | [ , A / æ c ^ A [ - A F E A \* ] { A E A G I A \* } {  
 AU' ^ • • ~ / ^ A | [ • • A à ^ c , ^ ^ } Aã } | ^ c Aæ } âA [ ~ c / ^ c k  
 A A Ø | [ , A Ç \* ] { D A F E A F I A G E A G I A G I  
 A A Ú • â A | [ • • A H E I A T E G A F G A F I E I A G I

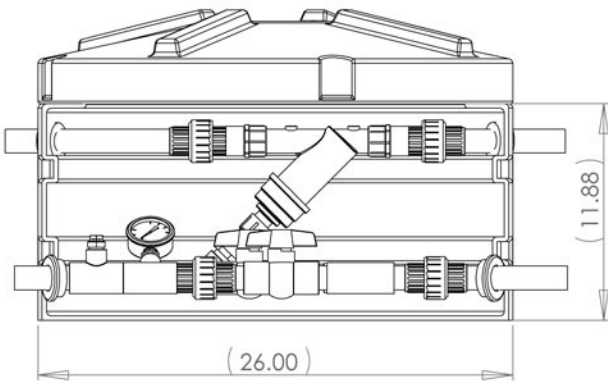

5i hca UHYX'8fjd'A Ubu Ya Ybh

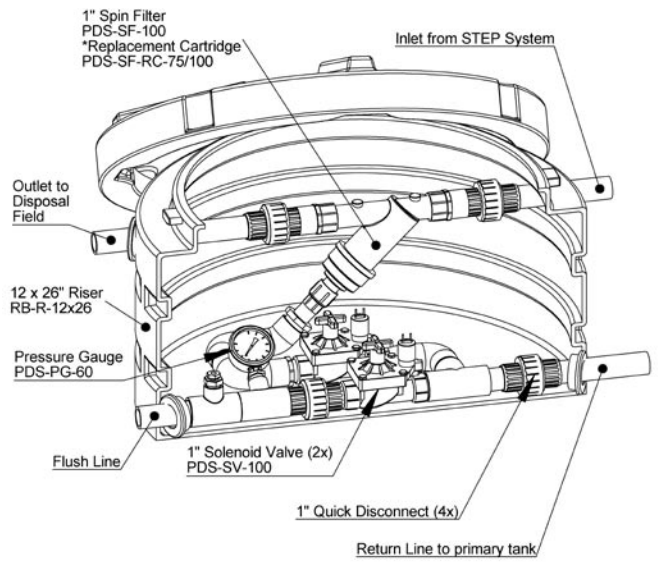

A Ubi U'8fjd'A Ubu Ya Ybh

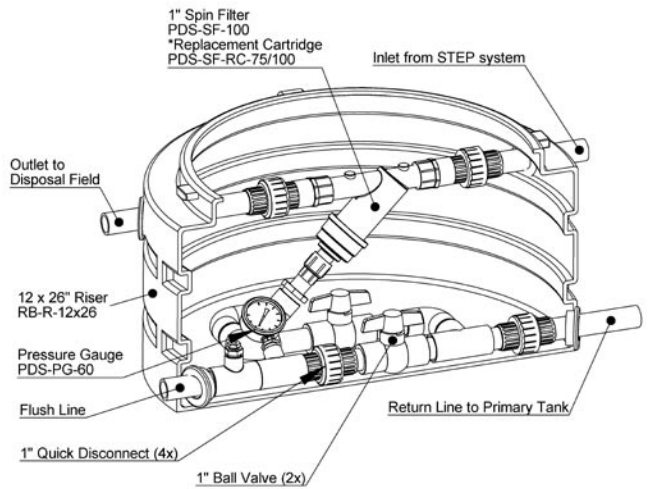

## AUbiU' a cXYg'bw iXY.

AU]ã } A , | c ^ !  
 AV [ A âæ | | A çæ | ç ^ •  
 AU' ^ • • ~ / ^ A \* æ ~ \* ^  
 ACEã | A / ^ æ • ^ çæ | ç ^  
 AU' ã & \ A âã • & [ ] } ^ & c •  
 AG I + A ç A FG + A [ | ^ c @ ^ | ^ } ^ à æ • ã } Aæ } â A | ãã

## 5ihcaUHYX' a cXYg'bw iXY.

AU]ã } A , | c ^ !  
 AV [ A • [ | ^ ] [ â â | çæ | ç ^ •  
 AU' ^ • • ~ / ^ A \* æ ~ \* ^  
 ACEã | A / ^ æ • ^ çæ | ç ^  
 AU' ã & \ A âã • & [ ] } ^ & c •  
 AG I + A ç A FG + A [ | ^ c @ ^ | ^ } ^ à æ • ã } Aæ } â A | ãã

Warranty for Defects in Material and Workmanship  
 Ç All components in system - 1 Year  
 AutoCad dwg files at [www.quanics.net](http://www.quanics.net)

% , ++ ! E I 5B = 7G ! k k k "ei Ub]Mj' bYh



i cee [ ð U ~ æ } æ • ^ } & ð c E | | ã } ð • ð • | ^ • ^ ç æ ã ð  
 U : [ â ~ ð c • ð æ & ç ^ ! ^ âã • ã ] ã | ã { | ^ ! ^ ð E ð  
 æ } ð [ | | ] c ^ ! } æ ð [ ] æ | | ^ c ^ } c ð ã U c @ ^ ! ^ ð E ð æ } ð ã  
 | ) c ^ ! } æ | | æ | | æ ^ ç æ • ã { æ } ã ã | ^ } ã } ð



