

Distribution Boxes

Features

- Equal flow and drop boxes for distributing effluent to drain fields
- Use in conjunction with Speed Levelers to achieve optimum distribution
- Each box includes appropriate number of patented snap-in seals
 GDS-DB-7L includes 1 SCH 40, 6 SDR 35 and 2 Plugs
 GDS-DB-9L includes 1 SCH 40, 8 SDR 35 and 2 Plugs

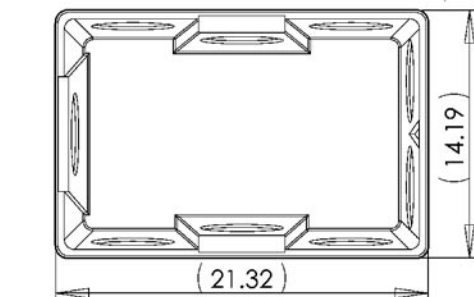
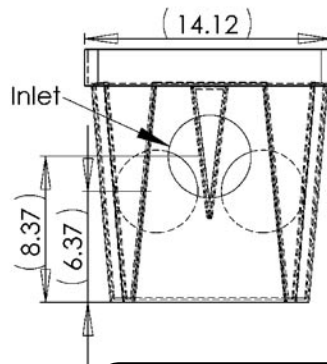
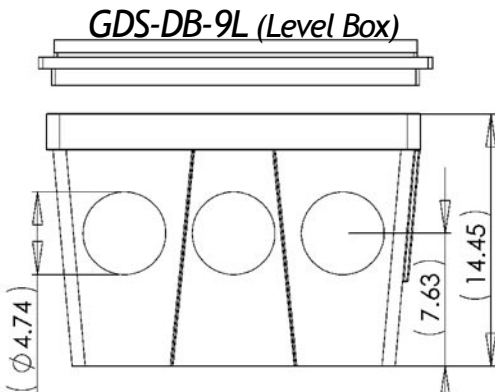
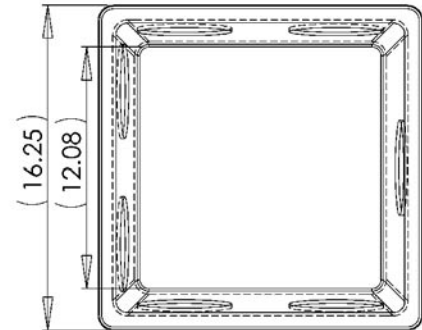
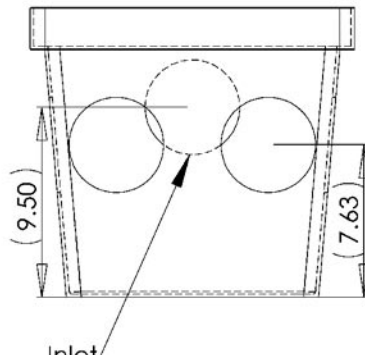
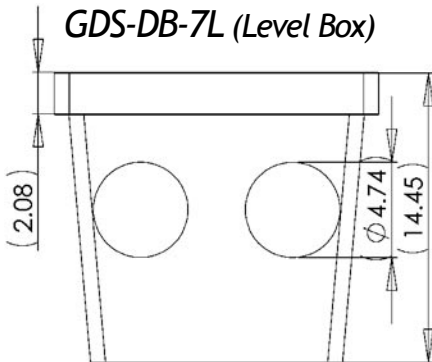
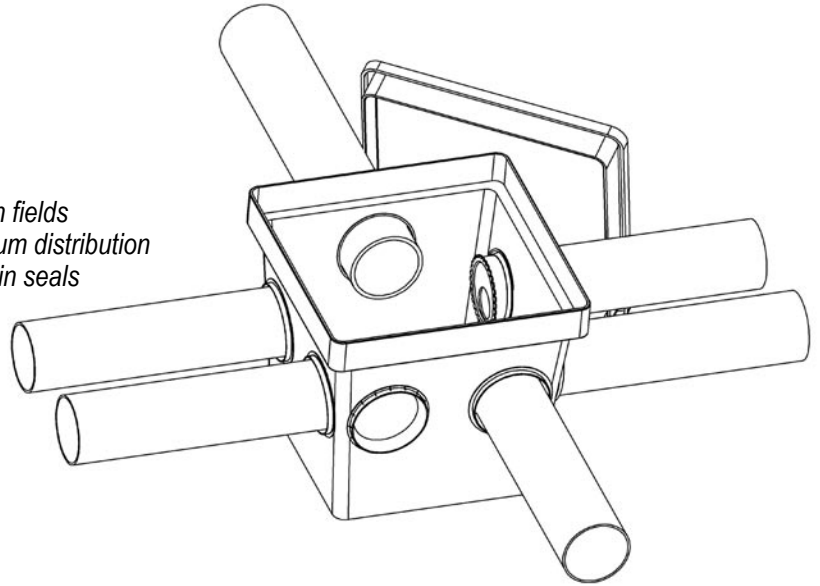

Materials:
 Injection molded high density polyethylene plastic
Warranty for Defects in Material and Workmanship
 • 1 Year
 AutoCad dwg files at www.quanics.net

1-877-QUANICS - www.quanics.net



© 2007, Quanics Inc. All rights reserved.
 Product(s) covered by one or more U.S.
 and/or International patents. Other U.S. and
 International patents may be pending.

