



ADVANCED TREATMENT Modules

ATS-8-AC/BC

Features

- Single module treats up to 1000 gallon per day
- Single-piece fiberglass construction
- Utilizes AeroCell® open cell foam fixed media or Bio-COIR® natural COIR media
- Treats wastewater to secondary or tertiary levels
- Modules may be added in sequence for greater flows at initial install or at a later date

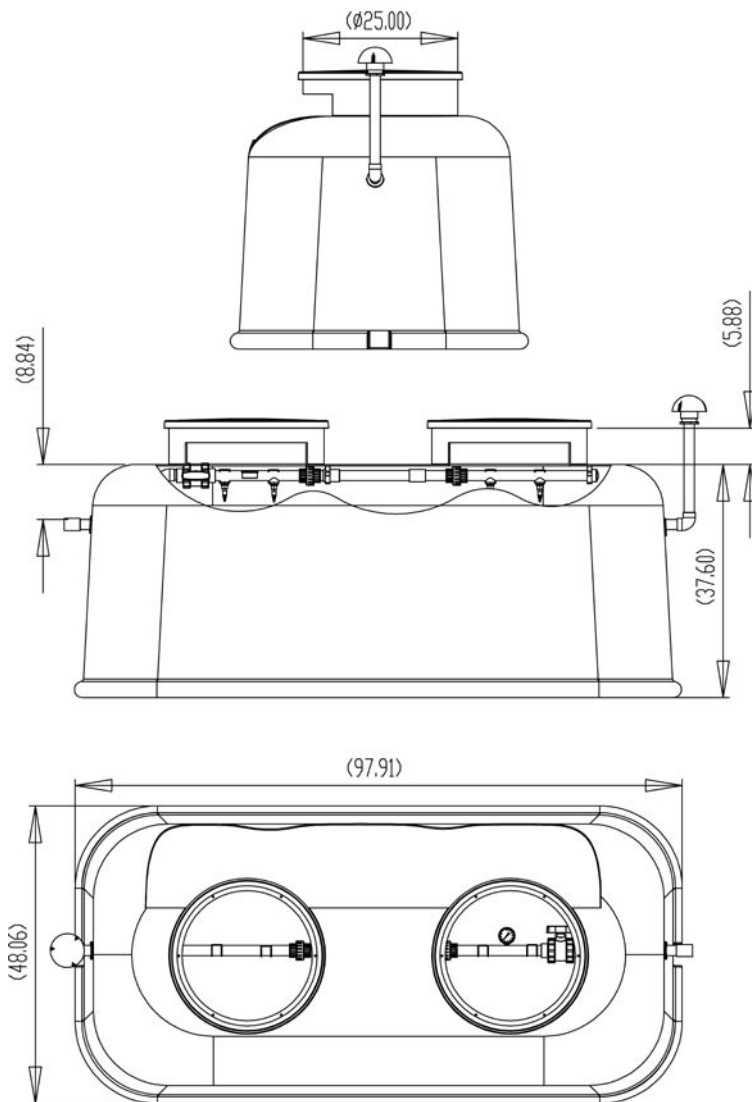
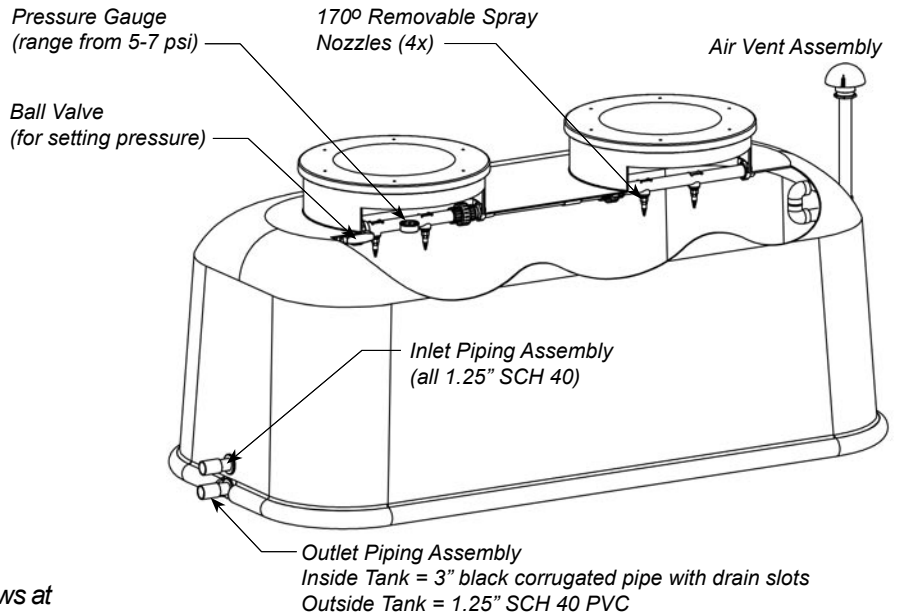

Materials

Treatment module

- ISO resin for corrosion and chemical resistance
- Nominal 3/16" wall thickness
- Sealed interior and exterior finish with no laminate exposure
- Stainless steel tamper resistant hardware
- Two high density polyethylene domed lids w/security screws

Effluent discharge and vent assembly

- 1.25" SCH 40 PVC intake and discharge piping
- Oil-filled pressure gauge
- Ball valve
- Four PVC snap-on spray nozzles
- Carbon filter vent

Treatment options

AeroCell® open cell foam

- 85 ft³ of open cell foam cubes
- Up to 12.5 gpd/ft³ hydraulic loading rate
- Max of .031 lbs/ft³/day organic loading rate
- Open cell foam contains 82% void space

Bio-COIR® natural media

- 85 ft³ of media
- Up to 12.5 gpd/ft³ hydraulic loading rate
- Max of .031 lbs/ft³/day organic loading rate
- Fibrous media 45% lignin for superior resistance to biodegradation

Warranty for Defects in Material and Workmanship

- Fiberglass module and spray assembly - 2 years
- Effluent discharge and vent assembly - 2 years
- Open cell foam media - 10 years
- COIR media - 2 years

AutoCad dwg files at www.quanics.net

1-877-QUANICS - www.quanics.net

Quanics
Engineering Water Solutions®

© 2008, Quanics Inc. All rights reserved.
Product(s) covered by one or more U.S.
and/or International patents. Other U.S.
and International patents may be pending.

DOWNLOAD
AutoCAD
DRAWINGS